

1.10 Managing Weeds

Introduction	3
Instructor's Lecture 1 Outline: Weed Biology	5
Detailed Lecture 1 Outline for Students	7
Instructor's Lecture 2 Outline: Cultural Weed Management Practices	11
Detailed Lecture 2 Outline for Students	15
Demonstration 1: Mechanical Weed Management	19
Instructor's Demonstration Outline	19
Demonstration 2: Hand Weeding	21
Instructor's Demonstration Outline	22
Demonstration 3: Weed Identification	23
Instructor's Demonstration Outline and Lab Exercise	24
Assessment Questions and Key	25
Resources	27
Appendices	
1. Hand Tools for Weed Management	29
2. Tools for Mechanical Weed Management	30

Introduction: Ecological Weed Management

UNIT OVERVIEW

Managing weeds with organically acceptable techniques is one of the biggest challenges that organic growers face. This unit introduces students to the basic biology of common weed plants found in agricultural systems, and the concepts and strategies used to effectively minimize weed pressure in sustainably managed annual vegetable cropping systems. The lecture material emphasizes field-scale weed management. Demonstrations also address hand-weeding techniques and tools used in a garden or small farm setting, as well as weed identification skills.

MODES OF INSTRUCTION

- > LECTURES (2 LECTURES, 1.5 HOURS EACH)
Lecture 1 presents basic weed biology, including the problems and benefits of weeds, as well as weed classifications and factors affecting germination and dispersal. Lecture 2 presents information on cultural practices commonly used in sustainable systems for weed management.
- > DEMONSTRATION 1: MECHANICAL WEED MANAGEMENT (1 HOUR)
The instructor's outline details how to demonstrate the various tractor-mounted tools used for field-scale cultivation of fallow and planted beds.
- > DEMONSTRATION 2: HAND WEEDING IN THE GARDEN AND SMALL FARM (1 HOUR)
The instructor's outline details how to demonstrate the use and maintenance of various hand tools for managing weeds in the garden and small farm.
- > DEMONSTRATION 3: WEED IDENTIFICATION LAB EXERCISE (1 HOUR)
With the instructor's guidance and the use of texts and web-based resources, students will learn to collect and identify common weeds at various growth stages.
- > ASSESSMENT QUESTIONS (1–2 HOURS)
Assessment questions reinforce key unit concepts and skills.
- > VIDEO PRESENTATION (1 HOUR)
See Resources section for recommended videos.

LEARNING OBJECTIVES

CONCEPTS

- The need for managing weeds in cropping systems
- The biology of weeds

SKILLS

- How to identify weeds
- How to design a cropping rotation specifically for weed management
- How to manage a cropping system for maximum weed suppression
- How to assess a cropping system for potential weed problems

Lecture 1 Outline: Weed Biology

for the instructor

A. Pre-Assessment Questions

1. What is a weed?
2. How are weeds dispersed?
3. What are some benefits of weeds in a cropping system?
4. What are some of the characteristics of weeds that allow them to compete so well in cropping systems?
5. Why control weeds?

B. Definition—What Is A Weed?

1. A weed is a plant that does more harm than good and has a habit of encroaching where it is not wanted

C. Weed Problems

1. Crop competition and its effect on crop yield and quality
 - a) Nutrient competition
 - b) Light competition
 - c) Water competition
2. Interference with harvesting operations
3. Allelopathic effect
4. Ability of weeds to reproduce in cropping systems
5. Weeds can harbor diseases and pests

D. Weed Benefits

1. Provide vegetative cover and thus minimize erosion
2. Enhance biological activity and soil tilth through additional organic matter: Root exudates and residues
3. Cycle nutrients
4. Indicate soil characteristics
5. Provide habitat for beneficial insects
6. Improve soil water infiltration

E. Weed Biology

1. Life-habit classification (give examples of each)
 - a) Annuals
 - i. Summer annuals (e.g., pigweed, lambsquarters, purslane)
 - ii. Winter annuals (e.g., chickweed, yellow mustard, annual bluegrass)
 - b) Biennials (e.g., bullthistle, wild carrot, poison hemlock)
 - c) Perennials
 - i. Simple perennials (reproduce by seed, e.g., dandelion, curly dock, plantain)
 - ii. Creeping perennials (reproduce by seed and by vegetative structures that can propagate new plants asexually)

2. Plant-type classification (give examples)
 - a) Grasses (monocots, e.g., annual bluegrass, johnson grass)
 - b) Broadleaves (dicots, e.g., pigweed, black mustard)
 - c) Brushes (e.g., coyote brush)
 - d) Woody plants (e.g., willow)
3. Daylength classification (give examples)
 - a) Short-day weeds
 - b) Long-day weeds
 - c) Day-neutral weeds
4. Seed germination
 - a) Factors affecting seed dormancy and germination include type of seed coat, temperature, moisture, oxygen, light, and presence of chemical inhibitors
5. Dispersal
 - a) Weed seed dispersal mechanisms
 - i. Wind
 - ii. Irrigation water, seed
 - iii. Importation on farm equipment
 - iv. Compost and animal manures
 - v. Facilitated by birds, gophers, and other animals
 - vi. Contaminated crop seed

Detailed Lecture 1 Outline: Weed Biology

for students

A. Pre-Assessment Questions

1. What is a weed?
2. How are weeds dispersed?
3. What are some benefits of weeds in a cropping system?
4. What are some of the characteristics of weeds that allow them to compete so well in cropping systems?
5. Why control weeds?

B. Definition—What is a Weed?

1. A weed is any plant, native or non-native, that interferes with crop production by doing more harm than good and has a habit of encroaching where it is not wanted

C. Weed Problems

1. Crop competition and its effect on crop yield and quality
 - a) Nutrient competition: Weedy plants, like crop plants, use soil nutrients for growth. Weeds can outcompete crops for essential plant nutrients, resulting in lower yields and/or poor crop quality.
 - b) Light competition: Weedy plants, like crop plants, use light for growth. Weeds can outcompete crops for sunlight, resulting in lower yields and/or poor crop quality.
 - c) Water competition: Weeds can outcompete crops for water, resulting in unnecessary water use, lower yields, and/or poor crop quality
2. Interference with harvesting operations
 - a) Example: Weed roots such as bindweed wrap around sub-soil blades used for undercutting root crops during harvest
3. Allelopathic effect of weeds on crop germination and growth: Certain weedy plants produce and secrete chemical compounds that are known to retard the germination of crop seed and the growth of crop plants
4. Ability of weeds to reproduce in cropping systems: Due to the high fertility and irrigation used in agricultural soils, weedy plants can themselves produce abundant seed and create a very large seed bank in a single season.
5. Weeds can harbor diseases such as viruses and plant pathogenic fungi

D. Weed Benefits

1. Enhance soil structure: Weed cover in a cropping system can enhance soil structure by protecting the soil surface from heavy rain, minimizing surface soil particle dispersion, and thus minimizing erosion
2. Improve soil tilth: Weeds can indirectly help improve soil tilth and aggregation by enhancing soil microbial activity through root exudates during growth and by providing additional residue at time of incorporation
3. Cycle nutrients: Like intentionally planted cover crops, weeds can retain mobile soil nutrients such as nitrate and prevent them from leaching during rains. Some weedy plants are able to access and concentrate certain soil nutrients making them available for subsequent crop growth.
4. Indicate soil characteristics: Certain species of weedy plants are known to grow only in soils with certain nutrient profiles, hydrology, and/or physical properties (see *Start With the Soil* by Grace Gurshuney pp. 18-20)

5. Provide habitat for beneficial insects: Weeds can be important habitat for beneficial insects by providing nectar, pollen, and places to breed
6. Improve soil water infiltration: Weeds can improve soil water infiltration by providing channels for water movement from decaying roots

E. Weed Biology

1. Life-habit classification

- a) Annual: A plant that completes its life cycle (germination through death) in one year or growing season, essentially non-woody
 - i. Examples of summer annuals
 - Pigweed (*Amaranthus* spp.)
 - Lambsquarters (*Chenopodium album*)
 - Purslane (*Portulaca oleracea*)
 - ii. Examples of winter annuals
 - Common chickweed (*Stellaria media*)
 - Yellow mustard (*Brassica* spp.)
 - Annual bluegrass (*Poa annua*)
- b) Biennial: A plant that completes its life cycle (germination through death) in two years or growing seasons (generally flowering only in the second), is non-woody (at least above ground), often with a rosette the first growing season
 - i. Examples of biennials
 - Bullthistle (*Cirsium vulgare*)
 - Wild carrot (*Daucus* spp.)
 - Poison hemlock (*Conium maculatum*)
- c) Perennial: A plant that lives for a number of years, often producing seed each year once it reaches maturity
 - i. Simple perennials that reproduce by seed
 - Dandelion (*Taraxacum officinale*)
 - Curly dock (*Rumex crispus*)
 - Plantain (*Plantago* spp.)
 - ii. Creeping perennials: Reproduce by seed and asexually through rhizomes, stolons, tubers, and rootstalk
 - Johnson grass (*Sorghum halepense*)
 - Bermuda grass (*Cynodon dactylon*)
 - Nutsedge (*Cyperus* spp.)
 - Field bindweed (*Convolvulus arvensis*)

2. Plant-type classification

- a) Grasses (monocots): Members of a subclass of Angiosperms characterized by the presence of one cotyledon in their seeds
 - i. Annual bluegrass
 - ii. Johnson grass
- b) Broadleaves (dicots): Members of a subclass of Angiosperms characterized by having two cotyledons in their seeds
 - i. Pigweed
 - ii. Black mustard (*Brassica* spp.)
- c) Bushes
 - i. Coyote brush (*Baccharis pilularis*)

- d) Woody plants
 - i. Willow (*Salix* spp.)
- 3. Daylength classification
 - a) Short-day weeds: Weeds that increase in vegetative growth when days are long and flower when days are short
 - i. Lambsquarters
 - b) Long-day weeds: Weeds that increase in vegetative growth when days are short and flower when days are long
 - i. Henbane
 - c) Day-neutral weeds: Weeds that flower under any photoperiod conditions
 - i. Nightshade (*Solanum* spp.)
- 4. Seed germination
 - a) Factors affecting seed dormancy and germination
 - i. Type of seed coat
 - ii. Temperature, moisture
 - iii. Oxygen
 - iv. Light
 - v. Presence of chemical inhibitors
- 5. Dispersal: Seed and plant movement
 - a) Weed seed dispersal mechanisms
 - i. Wind: It is critical to work with neighbors to reduce or eliminate weedy plants from surrounding areas in order to avoid wind-dispersed contamination
 - ii. Seed movement in irrigation water: Critical to have filters on irrigation system to avoid contamination
 - iii. Seed importation on farm equipment: Critical to clean equipment when moving from one field to another or borrowing equipment
 - iv. Seed importation through compost and animal manures: Critical to thoroughly compost materials aerobically prior to application while sustaining temperatures of 131°F+ for a minimum of 15 days
 - v. Movement facilitated by birds, gophers, and other animals
 - vi. Use of contaminated crop seed: Critical to check seed source for percent pure seed. Always use high quality seed supply.

Lecture 2 Outline: Cultural Weed Management Practices

for the instructor

A. Pre-Assessment Questions

1. How can crop rotations be used to minimize weed pressure?
2. What tools do growers use to mechanically control weeds?
3. What steps can be taken to minimize weed seed dispersal?

B. Weed Prevention Strategies

1. Improve soil tilth, aeration, water infiltration, and fertility to optimize crop growth and minimize weed pressure
2. Thoroughly clean equipment before moving it from one farm or location to another to avoid transporting weed seeds from infested fields
3. Do not allow weeds to form seed heads and/or perennial rooting structures in the cropping system
4. Thoroughly compost all imported animal manure to insure destruction of viable weed seed
5. Filter surface irrigation water to avoid importing weed seeds
6. Work with neighbors to eliminate or minimize the potential for spread of noxious and problematic weeds from adjacent lands

C. Crop Rotation Strategies for Optimum Weed Management

1. Rotate between summer and winter production systems
2. Use weed-suppressive cover crops in your rotation to suppress problem weeds
 - a) Examples of weed-suppressive cover crops
 - i. Sudan grass (*Sorghum bicolor*)
 - ii. Buckwheat (*Fagopyrum esculentum*)
 - iii. Sesbania (*Sesbania macrocarpa*)
 - iv. Annual rye grass (*Lolium multiflorum*)
 - v. Perennial rye grass (*Lolium perene*)
3. Use smother production crops and crops that compete well with weeds when weed pressure becomes high
 - a) Examples: Corn, winter squash, potatoes
4. Optimize timing of cover crop planting to insure strong uniform growth

D. Tillage Strategies to Minimize Weed Pressure

1. Maintain good soil structure
 - a) Minimize the use of rototillers to maintain good aggregation
 - b) Work soil at optimum moisture content to avoid compaction (see Unit 1.2, Garden and Field Tillage and Cultivation)
2. Use moldboard plows selectively to bury problem weed seeds

E. Planting and Cultivation Techniques to Minimize Weed Pressure

1. Plant large-seeded crops (e.g., corn, beans, squash) to moisture and don't irrigate until necessary
2. Plant straight, perfectly spaced seed lines on straight, firm, uniform beds to allow for ease and accuracy of cultivation
3. Use sleds or other guidance systems to keep implements tracking straight
4. Use transplants where practical to get a jump on weeds
5. Keep weed cultivations (either tractor mounted or hand held) shallow to avoid bringing up new weed seeds from lower soil horizons
6. Pay close attention to soil moisture, tith, and weed growth to optimize timing of cultivation
7. "Dirting": Weed cultivation where soil is moved to cover and smother weeds adjacent to crop plants

F. Irrigation Techniques to Minimize Weed Pressure

1. Pre-irrigate beds and lightly cultivate prior to planting to destroy newly germinated weeds
2. Maintain uniform irrigations to avoid areas of high water concentration
3. Use drip tape to avoid wetting the entire soil surface
4. Allow deep-rooted crops to establish deep root systems and irrigate deeply and infrequently to avoid excessive surface wetting
5. Delay irrigation following cultivation long enough to allow for weeds to desiccate

G. Fallow Period for Perennial Weed Control

1. Use a fallow period to control problem perennials
 - a) Use a springtooth cultivator during fallow periods to bring perennial weed roots to surface for desiccation and/or freezing

H. Flame Weeding Techniques and Strategies

1. Pre-irrigate "stale" beds (beds that have been formed but not planted) to germinate weeds and use flame weeder to kill newly germinated broadleaf weeds prior to planting crops
2. Use flame weeder on beds of slow-germinating crops such as garlic and carrots after irrigation and before crop emergence to kill newly germinated broadleaf weeds
3. Flamers are only effective on very small newly germinated broadleaf weeds with no surface moisture (dew) on leaves

I. Soil Solarization

1. How to solarize
 - a) Soil must be irrigated and saturated to at least 70% of field capacity to a depth of 24 inches prior to tarping
 - b) Lay 2 ml clear plastic tarp as close to smooth soil surface as possible during warmest time of year
 - c) Plastic should be left in place for 4 to 6 weeks
 - d) Tillage deeper than 3 inches must be avoided after solarization
2. Results of solarization
 - a) Solarization controls many annual weeds, and is especially effective in controlling winter annuals
3. Limitations to soil solarization
 - a) Control of purslane, crabgrass, and many perennials may be difficult to achieve
 - b) Soil solarization is most effective in very hot summer areas (90°F+ conditions)
 - c) Costs associated with production on large acreage

J. Weed-Suppressive Mulches

1. Dark plastic mulches can be used as a weed-suppressive mulch in many cropping systems
 - a) Example: Strawberries

K. Organic and “Living” Mulches

1. Organic mulches
 - a) Straw, sawdust
2. Living mulches
 - a) Intercropping with a cover crop in main season crop, serving to prevent erosion and limit weed growth
 - b) Important in low- and no-till systems

Detailed Lecture 2 Outline: Cultural Weed Management Practices

for students

A. Pre-Assessment Questions

1. How can crop rotations be used to minimize weed pressure?
2. What tools do growers use to mechanically control weeds?
3. What steps can be taken to minimize weed seed dispersal?

B. Weed Prevention Strategies

1. Improve soil tilth, aeration, water infiltration, and fertility to optimize crop growth and minimize weed pressure. Fertile agricultural soils with good tilth promote ease of weed removal by hand and/or by mechanical cultivation.
2. Thoroughly clean equipment before moving it from one farm or location to another to avoid transporting weed seeds from infested fields
3. Do not allow weeds to form seed heads and/or perennial rooting structures in the cropping system. A single season of allowing weeds to set seed may create years of weed management problems. Annual preventive clean cultivation will exhaust the existing seed bank.
4. Thoroughly compost all imported animal manures to insure destruction of viable weed seed. Aerobically composted manures and plant materials in which temperatures are sustained at 131°F+ for 15 or more days should destroy all viable weed seed.
5. Filter surface irrigation water to avoid importing weed seeds
6. Work with neighbors to eliminate or minimize the potential for spread of noxious and problematic weeds from adjacent lands

C. Crop Rotation Strategies for Optimum Weed Management

1. Rotate between summer and winter production systems. Alternating ground from winter to summer production combined with the use of weed-suppressive cover crops further exhausts the weed seed bank.
2. Use weed-suppressive cover crops in your rotation to suppress problem weeds
 - a) Examples of weed-suppressive cover crops
 - i. Sudan grass (*Sorghum bicolor*): Heat-loving summer cover crop quickly grows to 8 feet, shades other weedy plants. Prevents successful weed reproduction, exhausting seed bank.
 - ii. Buckwheat (*Fagopyrum esculentum*): A fast-growing, broad leaf summer cover crop. Smothers weeds quickly such as Canada thistle, nutgrass, quack grass, etc.
 - iii. Sesbania (*Sesbania macrocarpa*): Vigorous growth in hot summer areas, outcompetes and shades weeds
 - iv. Annual rye grass (*Lolium multiflorum*)
 - v. Perennial rye grass (*Lolium perene*): Adapted to cooler areas (e.g., Pacific Northwest). Dense growth and allelochemicals suppress germination and growth of weedy species.
3. Use smother production crops and crops that compete well with weeds when weed pressure becomes high
 - a) Examples: Corn, winter squash, potatoes

4. Optimize timing of cover crop planting to insure strong uniform growth. Uniform plantings of cover crops assure uniform ground cover and canopy of shade, reducing viability of weed populations.

D. Tillage Strategies to Minimize Weed Pressure

1. Maintain good soil structure
 - a) Minimize the use of rototillers to maintain good aggregation. Agricultural soils with good tillage allow for ease of weed removal through hand and/or mechanical cultivation.
 - b) Work soil at optimal soil moisture content (~50% of field capacity) to avoid compaction (see Unit 1.2, Garden and Field Tillage and Cultivation)
2. Use moldboard plows selectively to bury problem weed seeds such as annual bluegrass. Deep burial of certain weeds is possible but should be done very selectively.

E. Planting and Cultivation Techniques to Minimize Weed Pressure

1. Plant large-seeded crops (e.g., corn, beans, squash) to moisture rather than irrigating them up. Planting such large-seeded crops to moisture and allowing the crop to become established prior to any irrigation prevents germination of weedy competitors and unnecessary cultivation. Though soil and climate dependent, many of the crops listed above can grow to near maturity without irrigation, if not completely dry-farmed.
2. Plant straight, perfectly spaced seed lines on straight, firm, uniform beds. Uniform spacing and straight lines of production crops reduces weed pressure by allowing close mechanical cultivation, thereby reducing costs associated with hand weeding.
3. Use sleds or other guidance systems on all tractor-mounted planters and cultivators. These will help create straight, perfectly spaced seed lines on straight, firm, uniform beds.
4. Use transplants where practical to get a jump on weeds. Because they are larger than recently germinated weed seeds, transplants are easy to recognize when cultivating weedy ground. The larger transplants are also more mature, leading to rapid growth and successful competition with weeds.
5. Keep weed cultivations (either tractor mounted or hand held) shallow. This will avoid bringing up new weed seeds from lower soil horizons.
6. Pay close attention to soil moisture, tillage, and weed growth to optimize timing of cultivation. Cultivating weeds at the right soil moisture (~50% of field capacity) and at the early stages of weedy growth when surface soils are in need of aeration allows for two essential cultivation tasks to be completed simultaneously, thereby avoiding soil compaction.
7. "Dirtting": Configure beds and seed lines so that dirt can be moved into the planted row with cultivation equipment on long-stemmed crops (e.g., tomatoes, potatoes, sweet corn, peppers). This "dirtting" technique will effectively smother newly germinated weeds within the plant row.

F. Irrigation Techniques to Minimize Weed Pressure

1. Pre-irrigate beds and lightly cultivate prior to planting to destroy newly germinated weeds. Repeated pre-irrigation and light cultivation passes may be used to exhaust the seed bank prior to planting the production crop in a known weedy area.
2. Maintain uniform irrigations to avoid areas of high water concentration. Uneven moisture will result in uneven germination and growth of weed populations, often leading to the need for repeated cultivations.
3. Use drip tape to avoid wetting the entire soil surface. Reducing the soil surface area exposed to moisture will reduce the surface area of land able to support weed populations.
4. Allow deep-rooted crops to establish deep root systems and irrigate deeply and infrequently to avoid excessive surface wetting. See above.

5. Delay irrigation following cultivation long enough to allow for weeds to desiccate. Certain weeds (e.g., purslane) may successfully re-root and grow after cultivation if irrigation reestablishes root-to-soil contact before the weeds die.

G. Fallow Period for Perennial Weed Control

1. Use a fallow period to control problem perennials (e.g., Johnson grass, crab grass, bermuda grass)
 - a) Use a springtooth cultivator during fallow periods to bring perennial weed roots to surface for desiccation and/or freezing

H. Flame Weeding Techniques and Strategies

1. Pre-irrigate “stale” beds (beds that have been formed but not planted) to germinate weeds and use flame weeder to kill newly germinated broadleaf weeds prior to planting crops
2. Use flame weeder on beds of slow-germinating crops such as garlic and carrots after irrigation and before crop emergence to kill newly germinated broadleaf weeds
3. Flame weeders are only effective on very small newly germinated broadleaf weeds with no surface moisture (dew) on leaves

I. Soil Solarization

1. How to solarize
 - a) Soil must be irrigated and saturated to at least 70% of field capacity to a depth of 24 inches prior to tarping
 - b) Lay 2 ml clear plastic tarp as close to smooth soil surface as possible during warmest time of year
 - c) Plastic should be left in place for 4 to 6 weeks
 - d) Tillage deeper than 3 inches must be avoided after solarization
2. Results of solarization
 - a) Solarization controls many annual weeds, and is especially effective in controlling winter annuals
3. Limitations to soil solarization
 - a) Control of purslane, crabgrass and many perennials may be difficult to achieve
 - b) Soil solarization is most effective in very hot summer areas (90°F+ conditions)
 - c) Cost of soil solarization over large acreage may be prohibitive

J. Weed-Suppressive Mulches

1. Dark plastic mulches can be used as a weed-suppressive mulch in many cropping systems
 - a) Example: Strawberries

K. Organic and “Living” Mulches

1. Organic mulches
 - a) Straw, sawdust
2. Living mulches
 - a) Intercropping with a cover crop in main season crop, serving to prevent erosion and limit weed growth
 - b) Important in low- and no-till systems to suppress weed growth during season (see Unit 1.2, Garden and Field Tillage and Cultivation)

Demonstration 1: Mechanical Weed Management

for the instructor

OVERVIEW

For this field demonstration, the instructor should have access to a wide range of tractor-mounted or drawn tillage and cultivating implements and the appropriate tractors for each of the implements. It also requires access to tillable land and existing diverse cropping systems and/or formed fallow beds spaced to match the equipment.

PREPARATION AND MATERIALS

Implements and tractors used in the demonstration should be set up adjacent to the demonstration site and parked to allow fast hook up and drop off.

PREPARATION TIME

0.5 hour

DEMONSTRATION TIME

1 hour

DEMONSTRATION OUTLINE

A. Demonstration of Row Crop Cultivation Implements

1. Examine lister bar, markers, and shovels
 - a) Explain the use of listers for bed formation
 - b) Discuss other options for forming beds
 - c) Explain the use of bed shapers
2. Do a field demonstration of a rolling cultivator
 - a) Run rolling cultivator down fallow beds
 - b) Discuss the various uses of the rolling cultivators for weed management in fallow and cropped systems.
3. Do a field demonstration of a row crop cultivator set up with sweeps and knives
 - a) Run cultivator down crop row
 - b) Discuss the various components of cultivator operation and set up

Demonstration 2: Hand Weeding in the Garden and Small Farm

for the instructor

OVERVIEW

This field demonstration provides a brief overview of the most common hand tools and techniques used to manage weeds on both a garden and small-farm scale. The instructor should have access to a wide range of hand tools for demonstrating field use and tool maintenance. The demonstration also requires access to tillable land and existing diverse cropping systems at various stages of development.

PREPARATION AND MATERIALS

- Hand tools
- Wheel hoe
- Reciprocating hoe
- Tined cultivators
- Glaser collinear hoe
- Sharpening tools (e.g., files) for hand tools
- Existing diverse cropping systems at various stages of crop development and soil moisture

PREPARATION TIME

1 hour

DEMONSTRATION TIME

2 hours

DEMONSTRATION OUTLINE

A. Tools and Techniques for Hand Weeding at the Garden and Small-Farm Scale

1. Briefly review weed prevention strategies (see Lecture 2 Outline)
2. Discuss and demonstrate why hand tools are used
 - a) Tractor-mounted/mechanical weed control devices aren't able to cultivate close enough to the stem of many irrigated crops
 - i. Show students bed of crops where mechanical implements are ineffective and hand tools necessary
 - ii. Review and discuss crops and cropping strategies where hand cultivation is less necessary or is needed infrequently (e.g., dry-farmed crops or large-seeded crops planted to moisture)
 - b) Exclusive hand tool use in garden settings
3. Discuss and demonstrate the use of various hand tools
 - a) Discuss the importance of timing weed cultivation to prevent reseeding and competition for nutrients, sunlight, and water
 - b) Discuss the importance of sharp hand tools
 - c) Discuss and demonstrate the importance of cultivating weeds and soil at proper soil moisture
 - d) Discuss the importance of cultivating weeds and soil at proper times of day to encourage weed desiccation
 - e) Demonstrate commonly used hand tools (see appendix 1, Hand Tools for Weed Management)
 - i. Wheel hoe
 - ii. Reciprocating hoe ("hula hoe" or "stirrup hoe")
 - iii. Tined cultivators
 - iv. Glaser Colinear hoe
4. Discuss and demonstrate maintenance and care of hand tools
 - a) Proper storage of hand tools for longevity
 - b) Sharpening of hand tools

Demonstration 3: Identification of Common Weeds

for the instructor

OVERVIEW

This demonstration introduces students to weed plant identification skills through field collection and the use of written and web-based resources for identification (see Resources section). Student will also be asked to research and share weed management information relative to the specimens collected. The instructor is encouraged to share his or her experience in managing the weed species identified.

PREPARATION AND MATERIALS

1. Gather multiple copies of printed identification guides (see Resources section).
2. Organize lab room with multiple computer stations for accessing web-based identification resources (see Resources section).
3. Ask students to gather as many unknown weedy plants as possible from gardens or fields.
4. Have students work in pairs to identify the common name of each of the weeds as well as gather cultural information regarding the management of each species. Cultural information on each specimen should include the following: Genus and species; life habit classification; soil indications; reproductive strategy; cultural controls for organic systems.

PREPARATION TIME

1 hour

DEMONSTRATION/LAB TIME

2 hours

DEMONSTRATION OUTLINE

A. Review the Identification Process

1. Ask student to share the name of the plant and the identifying characteristics
2. Identification is confirmed with other students and instructor
3. Instructor reviews identifying characteristics, if necessary

B. Ask Students to Share Additional Cultural Information

1. Where weed was found/habitat
2. Genus and species of weed
3. Life habit classification of weed
4. Soil physical or chemical properties as indicated by presence of particular weed species
5. Reproductive strategy and dispersal of weed
6. Cultural controls for organic systems

C. Instructor Shares His or Her Experience in Managing the Weed Species Identified

Assessment Questions

- 1) Describe common problems associated with the unmanaged growth of weedy plant species in the garden or farm.

- 2) What are five ways by which weed seeds are dispersed? Describe five preventive measures that may be used to avoid the dispersal of weed seeds in the garden and farm.

- 3) Describe two ways that crop rotation may be used to control weeds in organic farming systems.

- 4) Describe five planting and/or cultivation techniques used to minimize weed pressure.

- 5) Describe three irrigation techniques that may be used to minimize weed pressure in organic farming systems.

- 6) Describe three additional weed management techniques, how they function, and how they may be used in organic farming systems.

Assessment Questions Key

- 1) Describe common problems associated with the unmanaged growth of weedy plant species in the garden or farm.
 - *Crop competition for nutrients, water, and light*
 - *Interference with harvesting operations*
 - *Allelopathic effects on crop*
 - *Ability of weeds to rapidly reproduce in cropping systems*
 - *Weeds can harbor diseases and pests*
- 2) What are five ways through which weed seeds are dispersed? Describe five preventive measures that may be used to avoid the dispersal of weed seeds in the garden and farm.
 - *Wind: Manage vegetation prior to seed maturation; work with neighbors to minimize weed seed sources*
 - *Irrigation water: Water filter on irrigation equipment*
 - *Importation on farm equipment: Clean equipment before transporting to new fields*
 - *Compost and animal manure: Thoroughly aerobically compost all manure at high temperatures*
 - *Facilitated by birds, gophers, and other animals*
 - *Contaminated crop seed: Select certified seed with low weed seed content*
- 3) Describe two ways that crop rotation may be used to control weeds in organic farming systems.
 - *Smother crops and crops that compete well with weeds, e.g., corn, winter squash, potatoes*
 - *Weed-suppressive annual cover crops*
 - *Weed-suppressive perennial cover crops in rotation*
 - *Optimize timing of cover crop planting to insure strong uniform growth and a weed suppressive cover*
- 4) Describe five planting and/or cultivation techniques used to minimize weed pressure.
 - *Plant large-seeded crops to moisture*
 - *Plant straight, perfectly spaced seed lines on straight, firm, uniform beds to facilitate cultivation*
 - *Use sleds or other guidance systems on all tractor mounted planters and cultivators to assure uniform spacing, ease of close cultivation and “dirting”*
 - *Use transplants, where practical, to get a jump on weeds*
 - *Keep weed cultivations (tractor mounted or hand held) shallow to avoid bringing up new weed seeds*
 - *Timing of cultivation: Soil moisture, tilth, and weed growth. Cultivation should precede irrigation by enough time to assure desiccation of weeds. Good tilth allows for ease of weed removal; compacted soils encourage the growth of certain noxious weeds. Cultivation should precede weed seed maturity.*
- 5) Describe three irrigation techniques that may be used to minimize weed pressure in organic farming systems.
 - *Pre-irrigate beds and lightly cultivate prior to planting*
 - *Use drip tape to avoid wetting the entire soil surface*
 - *Allow deep-rooted crops to establish deep root systems and irrigate deep and infrequently to avoid excessive surface wetting*

6) Describe three additional weed management techniques, how they function, and how they may be used in organic farming systems.

- *Irrigate stale beds (beds that have been formed but not planted) to germinate weeds and use flame weeder to kill newly germinated broadleaf weeds prior to planting crops*
- *Use flamer on beds of slow-germinating crops such as garlic and carrots after irrigation and before crop emergence to kill newly germinated broadleaf weeds*
- *Soil solarization suppresses weeds by elevating soil temperatures high enough to kill weed seeds*
- *Dark plastic mulches suppress weeds by blocking light and as a physical barrier*

Resources

PRINT RESOURCES

Bowman, Gregg, ed. 1997. *Steel in the Field: A Farmer's Guide to Weed Management Tools*. Handbook Series Book 2. Burlington, VT: Sustainable Agriculture Network.

Includes drawings and explanations of numerous tractor implements used for mechanical weed management in sustainable cropping systems. Grower narratives give information on specific applications.

Fischer, Bill, ed. 1998. *Grower's Weed Identification Handbook*. Publication 4030. Oakland, CA: University of California Division of Agriculture and Natural Resources.

Detailed identification plates of over 272 California weed species.

Gershuny, Grace. 1993. *Start with the Soil*. Emmaus, PA: Rodale Press.

Includes a discussion of weeds as indicators of soil physical and chemical properties.

Smith, Richard, W. Thomas Lanini, Mark Gaskell, Jeff Mitchell, Steven Koike, and Calvin Fouche. 2000. *Weed Management for Organic Crops*. Publication 7250. Oakland, CA: University of California Division of Agriculture and Natural Resources.

Information on cultural practices, cultivation, flammings, soil sterilization, mulches, beneficial organisms, and chemical control of weeds.

Whitson, Tom, ed. 2000. *Weeds of the West, Fifth Edition*. Laramie, WY: Western Society of Weed Science and the University of Wyoming Cooperative Extension Service.

900 photographs of over 350 weed species of Arizona, California, Colorado, Hawaii, Idaho, Montana, Nevada, New Mexico, Oregon, Utah, Washington and Wyoming.

WEB RESOURCES

California Weed Science Society (CWSS)

www.cwss.org

CWSS promotes environmentally sound proactive research and develops educational programs in weed science, as well as educational activities to promote integrated weed management systems.

UC Integrated Pest Management Program

www.ipm.ucdavis.edu

Contains extensive information on IPM, including weed identification and management.

Western Society of Weed Science (WSWS)

www.wsweedsociety.org

WSWS works to promote weed science research and education; site includes job announcements, upcoming meetings, and links to additional weed management information.

VIDEOS

Cultural Weed Control in Vegetables. 1993. By Lanini, T. Program V93-E. Davis, CA. Oakland, CA: University of California Division of Agriculture and Natural Resources.

New Tools for Mechanical Weed Control in Vegetables. 1998. By Bellinder, R. and J. Colquhoun. 1998. Ithaca, NY: Cornell University

Vegetable Farmers and Their Weed Control Machines. 1997. By Grubinger, V. and M.J. Else 1997. Burlington, VT: University of Vermont and University of Massachusetts Extension.

Appendix 1: Hand Tools for Weed Management

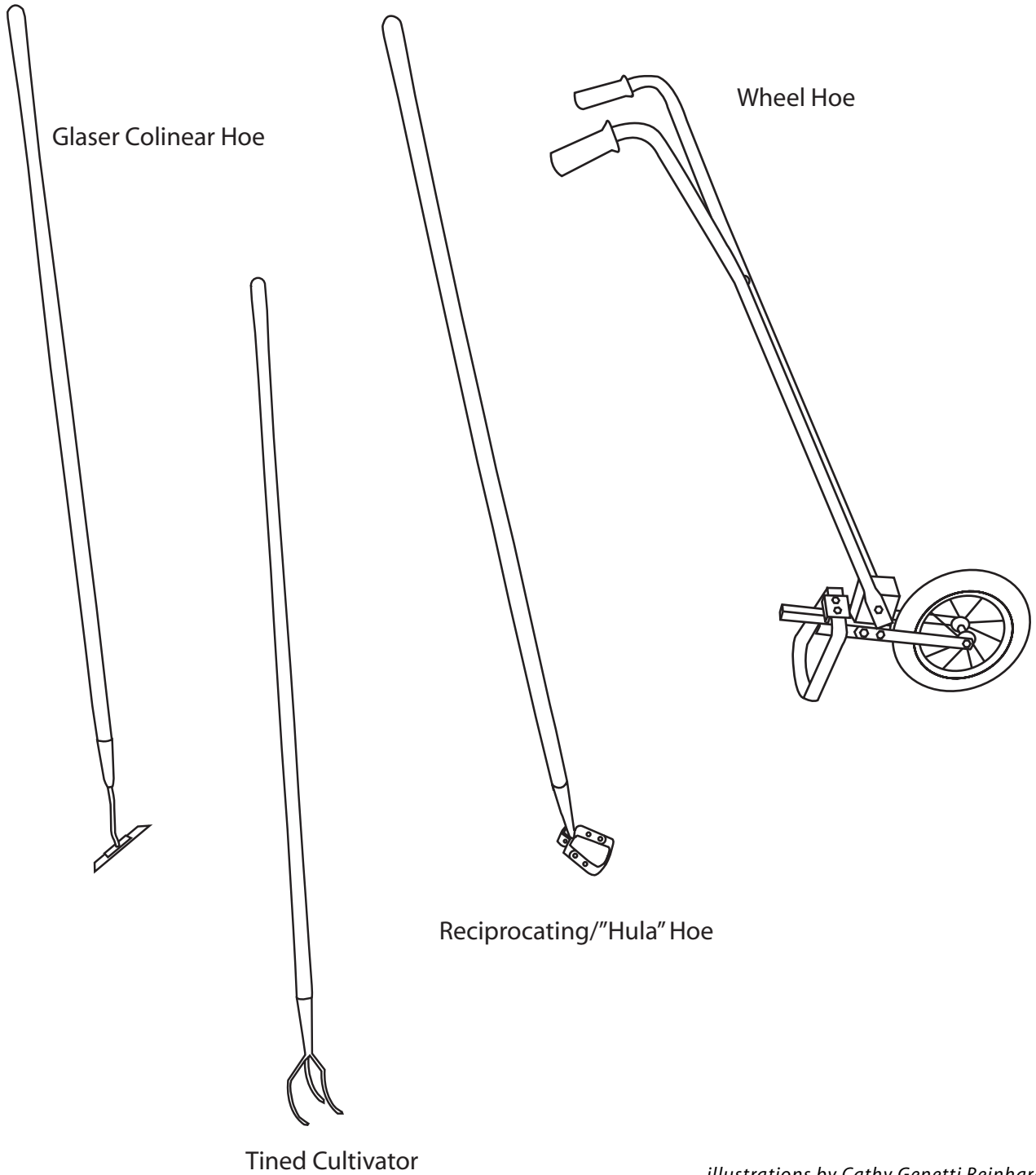

*illustrations by Cathy Genetti Reinhard;
not to scale*

Appendix 2: Tools for Mechanical Weed Management

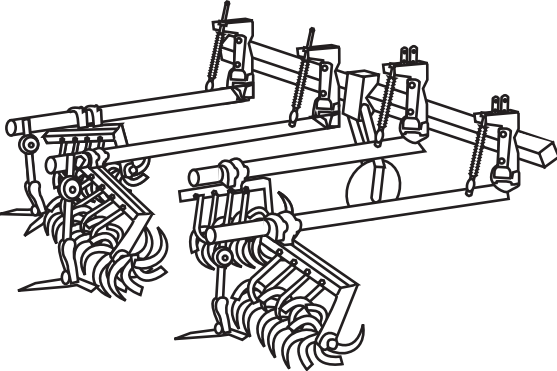

Lilliston Cultivator

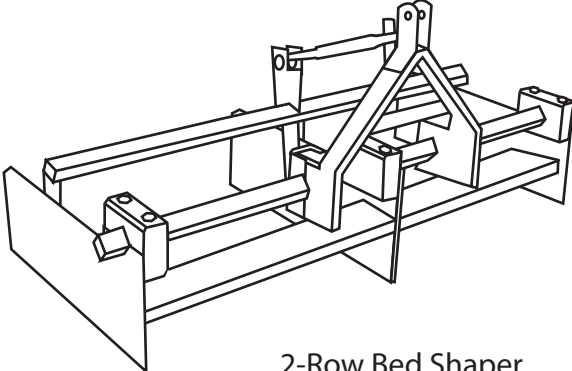

2-Row Bed Shaper

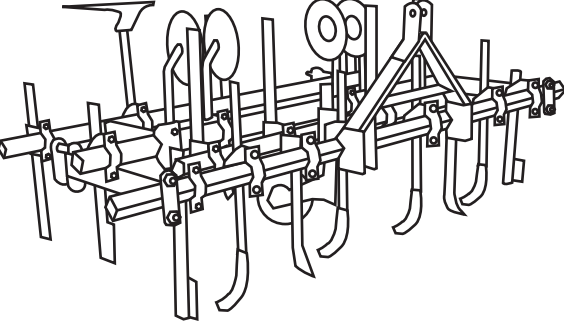

3-Bar Cultivator

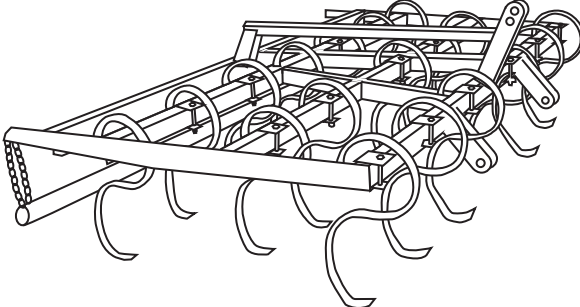

Spring-toothed Harrow

*illustrations by Cathy Genetti Reinhard;
not to scale*